

Procal  
1300 ACU MK5  
CEM AMS Control  
and Reporting



aerospace  
climate control  
electromechanical  
**filtration**  
fluid & gas handling  
hydraulics  
pneumatics  
process control  
sealing & shielding



## Procal 1300 ACU MK5

CEM AMS Control and Reporting



# Overview

The Procal 1300 Analyser Control Unit (ACU MK5) forms the hub of an advanced Continuous Emission Monitoring System (CEMS).

In addition to collecting data from Procal's advanced range of Continuous Emission Monitoring Analysers, it is configured to receive data from complementary devices, e.g. dust / opacity, oxygen and flow. This enables the system to display gas concentration on a normalised basis and, if required, in mass units e.g. kg/hour.

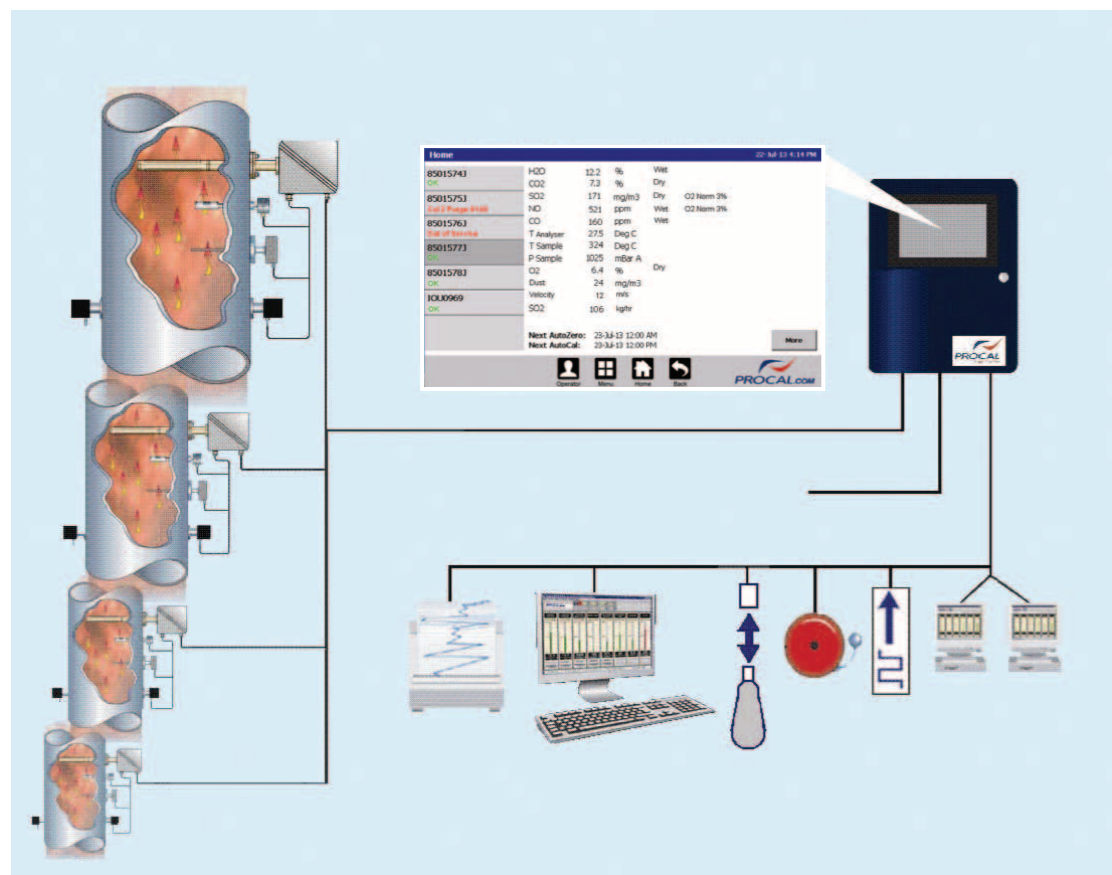

The Analysers communicate via a serial data link to the Procal 1300 (ACU MK5) which can be located up to 1200 m from the stack mounted CEMS. To facilitate ease of operation, the intuitive software runs under Windows CE and the HMI utilises touch screen controls for all operator functions.

The Procal 1300 series is capable of supporting up to four Procal Analysers with associated third part devices. The Procal 1300 unit forms the heart of a sophisticated Continuous Emissions Monitoring System, displaying monitored gases and particulate concentrations, (O<sub>2</sub> Normalised and on a WET / DRY basis if required) and transmitting the data in industrial standard formats. The Procal 1300 fulfils the analyser control functions, enabling for example the initialisation of an automatic or manual zero and calibration functions, in-situ sample heater temperature set point, output device assignment and alarm allocation / level. The unit also runs diagnostic routines on all analysers within the system with associated visual, MODBUS and contact closure alarms.

# Main Screen

Data from up to eight channels per instrument can be presented on an individual front panel comprising:

- Concentration / measurement value.
- Alarm configuration and levels.
- Alarm status.
- Normalisation (correction for carbon dioxide or oxygen).
- Wet / dry basis reporting.
- System diagnostic alarm with access to specific detailed displays.
- Autozero / calibration status.
- Analyser connection status and analyser-specific status panel screens for each instrument.

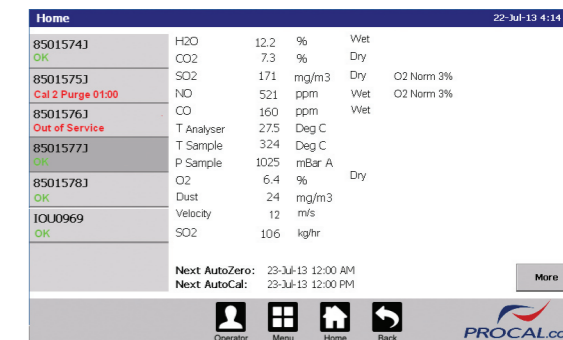

# Additional Screens

Various screens either analyser-specific or system can be accessed using the "soft" touch screen multi-function buttons. These include a "Test" screen as shown which enables the operator to check the health of the individual analysers. In addition the operator / service engineer can view and make adjustments through password protected menu and accessible screens.

These include for example:

- **Test** - One for each Analyser Unit (AU) showing all measured values.
- **Alarm** - Alarms for each channel can be assigned and designated.
- **Menu** - Multiples set-up menus for each analyser and the system.

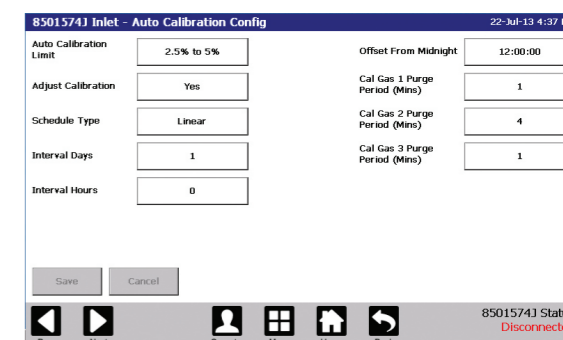

# System Capability

- Supports up to four (4) Procal Analysers each with up to four (4) third party inputs.
- MODBUS slave connectivity enabling the data from multiple Procal 1300 to be displayed and logged on a supervisory Procal 1000, enabling Trend reports. Hourly, excursion, daily and weekly averaging reports to be generated.
- MODBUS slave connectivity to plant DCS.
- Zero Calibration Status (Zero and Calibration report).
- PROFIBUS - Slave connectivity (optional)

# Procal 1300 Series - Environmental Protected Analyser Control Unit

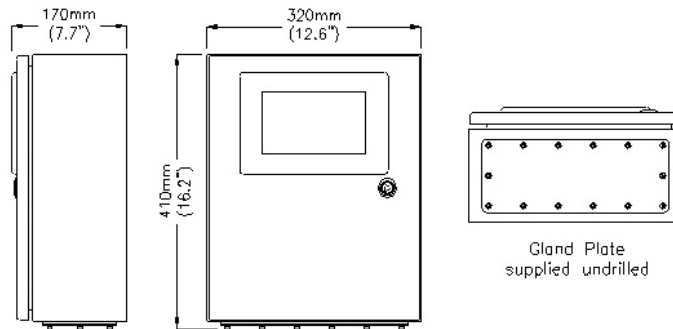

This unit has been specifically designed to be located in industrial environments giving the plant operator flexibility in the installation and operation of the CEM.

The hardware consists of an IP65 / NEMA 4X enclosure containing a high-grade, sealed touchscreen panel HMI with optional 4 - 20 mA I/O.

## I/O (Standard):

- Data Dump Facility - USB memory stick.
- MODBUS - Four wire RS485 Full Duplex, Standard MODBUS Slave
- LAN - Ethernet 10 / 100 / 1000 Mbps

## I/O (Optional Internal):

- Up to 20 Current Input / Outputs / Relays / Digital Inputs Select from:
  - Current Inputs / Outputs - 0 - 20 mA / 4 - 20 mA, each galvanically isolated from ground and from each other. Normally only fitted with the same number of outputs as the number of Procal ranges, third party instruments connected to the system can also be allocated outputs.
  - Relay Outputs Volt-Free 28 V dc 1 A (n/c or n/o selectable) for channel alarms, analyser 'fault' relay, and for other functions.
  - Digital Inputs 24 V / 20mA logic or Contact closure detection Link Selectable.
  - PROFIBUS - Slave Connectivity (optional).

## I/O (Optional External)

- A second I/O Unit can be connected externally doubling the available I/O capability.

Program medium:	Program and program update and trend / event storage SD Card 1 GB.
Enclosure:	Polyester powder coated mild steel, panel mounted, HMI, sealed to IP 65 / NEMA 4X.
Operating environment:	Operating temperature range: -10°C to +40°C (+ 14°F to + 104°F).
Enclosure classification:	Non-hazardous area.
Services required:	90 - 264 Vac, 47 - 63 Hz, 70 W Typical / 160 W Maximum (Dependent on options fitted).
Weight:	7.8 kg (17.2 lb) Dimensions 400 mm (H) x 300 mm (W) x 105 mm (D) 15.5" (H) x 11.8" (W) x 4.2" (D)